

SBK



SKANFLEX CORRUGATED SIDEWALLS

Skanflex corrugated sidewalls are available in heights from 40 to 600 mm. The sidewalls are extremely rigid in the transverse direction, which is significant for direct return support. In combination with lateral flexibility and strong resistance to wear-and-tear, the sidewalls are extremely wear- and impact-resistant, ensuring extended belt service life.

We offer Skanflex corrugated sidewalls as separate loose profiles and as cold or hot vulcanised elements on the belt (depending on the application).

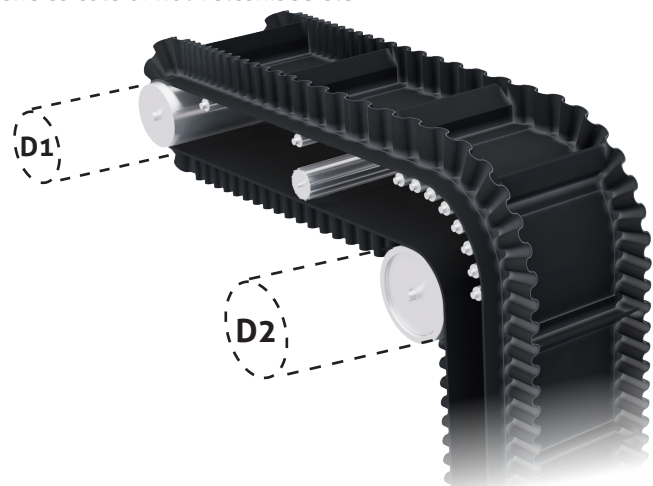
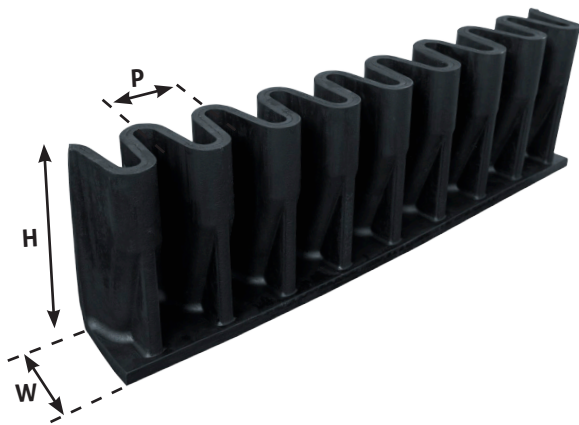

TYPE	HEIGHT mm	W mm	WEIGHT kg/m	P mtr.	D1 MIN. mm	D2 MIN. mm	QUALITY	
SL40	40	40	1,00	47	100	160	Y = Normal quality	To ensure optimal belt service life, D1 and D2 must be met.
SL60	60	40	1,40	47	150	240		
SL80	80	40	1,80	47	150	320		
S60	60	50	1,50	50	160	250	OIL-GM = Medium oil & fat resistant	Please note that the values stated are given for standard quality Y. For other qualities we recommend minimum D1 & D2 + 100 mm. Please contact us for details.
S80	80	50	1,85	50	240	320		
S100	100	50	2,30	50	300	400		
S120	120	50	3,70	50	325	480	OIL-GM-K = Flame + medium oil & fat resistant	Pulley diameters that are smaller than those stated in the tables will always shorten belt service life. If you increase pulley diameter, you can significantly prolong belt service life.
S140	140	50	3,10	50	400	560		
SW80	80	50	1,80	50	240	320		
SW100	100	50	2,30	50	300	400	T130-T150 = Heat resistant	The minimum pulley diameter for any given belt must always be selected in accordance with the largest pulley diameter, i.e. if the belt is Ø400 mm and selected corrugated sidewalls and/or cleat are 480 mm, you should select a minimum pulley diameter of 480 mm.
SW120	120	50	2,70	50	325	480		
SW140	140	50	3,10	50	400	560		
SWS120	120	75	4,00	60	360	480	K = Flame resistant	
SWS140	140	75	4,60	60	420	560		
SWS160	160	75	5,20	60	480	640		
SWS180	180	75	5,80	60	540	720	SW+SWS = Fabric reinforced	
SWS200	200	75	6,40	60	600	800		
SWS240	220	75	7,60	60	720	960		
SWS260	260	75	8,20	60	780	1.040	SWSF = Fabric reinforced - special heavy duty construction	
SWS280	280	75	8,80	60	840	1.120		
SWS300	300	75	9,40	60	900	1.200		
SWSF350	350	115	17,50	83	1.200	1.500		
SWSF400	400	115	19,90	83	1.400	1.800		
SWSF500	500	115	24,75	83	1.750	2.250		
SWSF600	600	115	29,60	83	2.100	2.700		

Skandinavisk Båndkompagni A/S

Birkegårdsvej 34A • DK 8361 Hasselager • Tel. +45 8734 7080 • info@sbk-belt.dk • www.sbk-belt.dk

Subject to alterations