

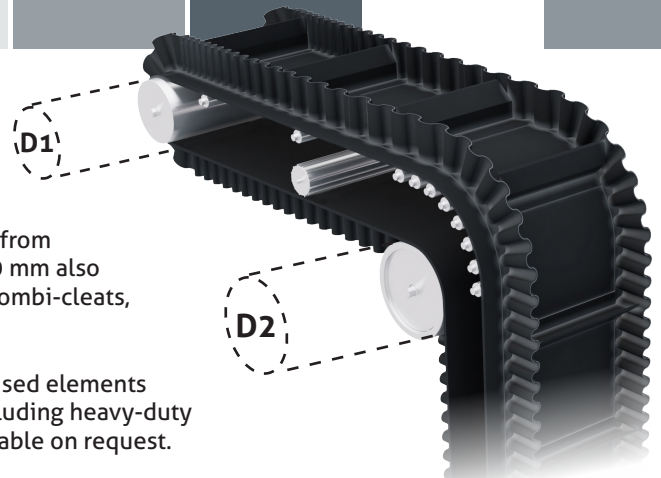



SKANCLEAT CLEATS

Skancleats cleats are moulded for strength and rigidity.

For lighter applications, we offer EKT extruded cleats (see table). Cleats from 110 mm can be supplied with textile reinforcement and cleats from 280 mm also with steel reinforcement. Cleats from 280 mm can also be supplied as combi-cleats, i.e. the cleat is subdivided into a base/foot and blade.

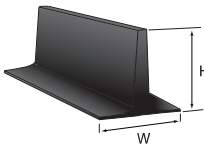
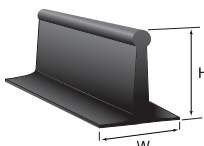
We offer Skancleats as separate loose profiles and as cold or hot vulcanised elements on the belt (depending on the application). Other sizes and designs, including heavy-duty block cleats, cleats attached to the belt with screws/bolts, etc., are available on request.

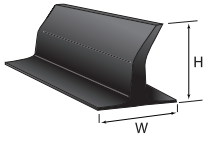
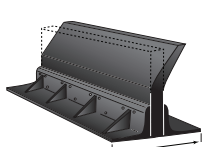

TYPE	HEIGHT mm	W mm	WEIGHT kg/m	Prod. length mtr.	D1 MIN. mm	D2 MIN. mm	QUALITY		
T-EKT 20	20	40	0,40	20,0	150	180	D = Fabric reinforced		To ensure optimal belt service life, D1 and D2 must be met. Please note that the values stated are given for standard quality Y. For other qualities we recommend minimum D1 & D2 + 100 mm. Please contact us for details.
T-EKT 40	40	70	0,70	4,0	150	200			
TT-EKT 55	55	80	1,0	4,0	160	250			
T-EKT 60	60	80	1,00	4,0	160	250			
T-EKT 75	75	100	2,55	4,0	200	300			
T-50	50	80	1,45	2,4	160	200	Y = Normal quality		Pulley diameters that are smaller than those stated in the tables will always shorten belt service life. If you increase pulley diameter, you can significantly prolong belt service life.
T-75	75	100	2,55	2,4	200	300			
T-90	90	100	2,80	2,4	240	375			
T-110 / TD-110	110	100	3,10	2,4	240	375	TT = Special cleat for "gentle" transport		The minimum pulley diameter for any given belt must always be selected in accordance with the largest pulley diameter, i.e. if the belt is Ø400 mm and selected corrugated sidewalls and/or cleat are 480 mm, you should select a minimum pulley diameter of 480 mm.
T-140 / TD-140	140	150	5,95	2,4	420	560			
T-160 / TD 160	160	150	6,45	2,4	480	640			
T-180 / TD-180	180	150	6,75	2,4	540	720	OIL-GM = Medium oil & fat resistant		
C-EKT 40	40	70	0,50	4,0	160	200			
C-EKT 60	60	80	1,25	4,0	160	250			
C-EKT 75	75	100	1,82	4,0	200	300			
C-75 / CD-75	75	85	1,80	2,4	200	300			
C-110 / CD-110	110	95	2,70	2,4	250	350	K = Flame resistant		
TC-75 / TCD-75	75	85	2,00	2,4	200	300			
TC-90 / TCD-90	90	110	2,65	2,4	220	325			
TC-110 / TCD-110	110	110	3,10	2,4	250	350	OIL-GM-K = Flame + medium oil & fat resistant		
TC-140 / TCD-140	140	150	5,80	2,85	420	560			
TCD-160	160	150	6,45	2,85	480	640			
TCD-180	180	150	7,10	2,85	540	720			
TCD-220	220	170	8,50	2,85	660	880			
TCD-240	240	170	9,15	2,85	720	960	T130-T150 = Heat resistant		
TCD-260	260	170	9,80	2,85	780	1.040			
TCD-280	280	170	10,40	2,85	840	1.120			
TCWD-280	280	280	19,70	2,4	950	1.300	WD = Fabric reinforced heavy duty combi-cleat		
TCWD-330	330	280	25,00	2,4	1.200	1.500			
TCWD-380	380	280	25,00	2,4	1.350	1.750			
TCWD-480	480	280	31,70	2,4	1.700	2.200			
TCWD-580	580	280	36,10	2,4	2.100	2.650			

We recommend that the cleats are 10-15 mm lower than the corrugated sidewalls !